

Related Products

MLX90316 Tria[®]is™ Rotary Position Sensor

Related Documents

Datasheet MLX90316

Applications Note Back-End Calibration

Applications Note Magnets for MLX90316 Rotary Position Sensor

Applications Note Hall Applications Guide

Related Tools

PTC04 Programmer for Melexis PTC devices

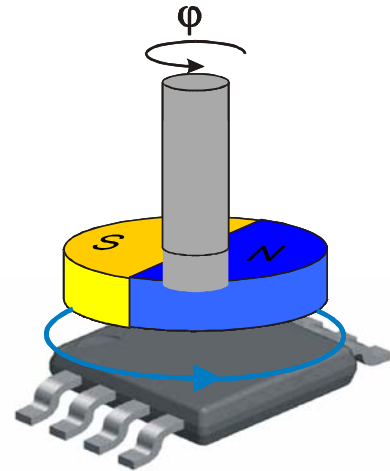

Ordering Information

Part No.	Description
EVB_MLX90316DC	Evaluation Board MLX90316xDC – SOIC-8 Package
EVB_MLX90316GO	Evaluation Board MLX90316xGO – TSSOP-16 Package
DMB_MLX90316	Demonstration Board MLX90316

1. Evaluation Board (EVB_MLX90316DC)

1.1. Description

The EVB_MLX90316DC consists into a Printed Circuit Board (PCB) and Magnetic Knob.

- The PCB implements the recommended application diagram from the MLX90316 datasheet. The MLX90316DC (SOIC-8) is mounted on the board. It also includes an aluminum ring in order to center the magnetic knob (see below) above the sensitive area of MLX90316. By default, the output transfer characteristic is programmed to get a 10%V_{dd} ... 90%V_{dd} analog output swing for 0 ... 360 Degrees travel (complete revolution).
- The magnetic knob features a small SmCo magnet diametrically magnetized D6H2.5 (Diameter = 6 mm and Height = 2.5 mm).

1.2. Application Diagram

The Pin SCLK and /SS are left floating in order to enable the use of the EVB in Serial Protocol mode. If this mode is not activated, we recommend shorting those pins to GND through 0 Ohm resistor. It is mandatory to run EMI test.

If the Serial Protocol mode is activated, the PCB allows the introduction of decoupling capacitor.

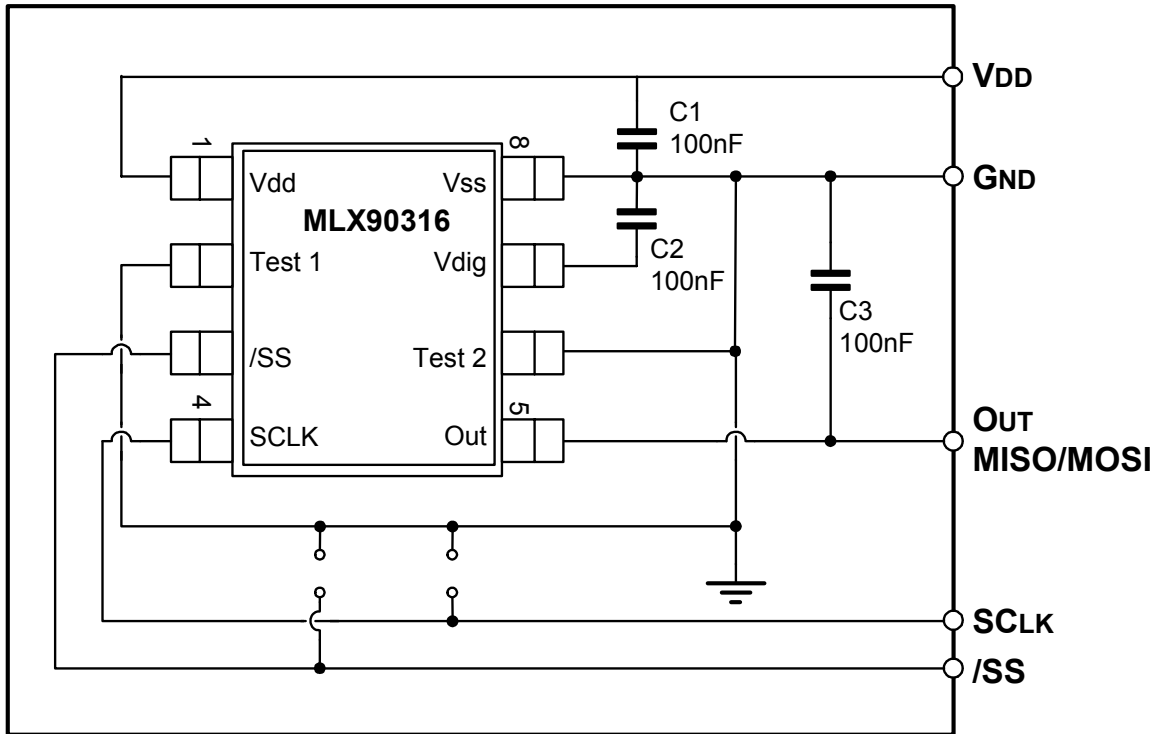

1.3. PCB Drawing

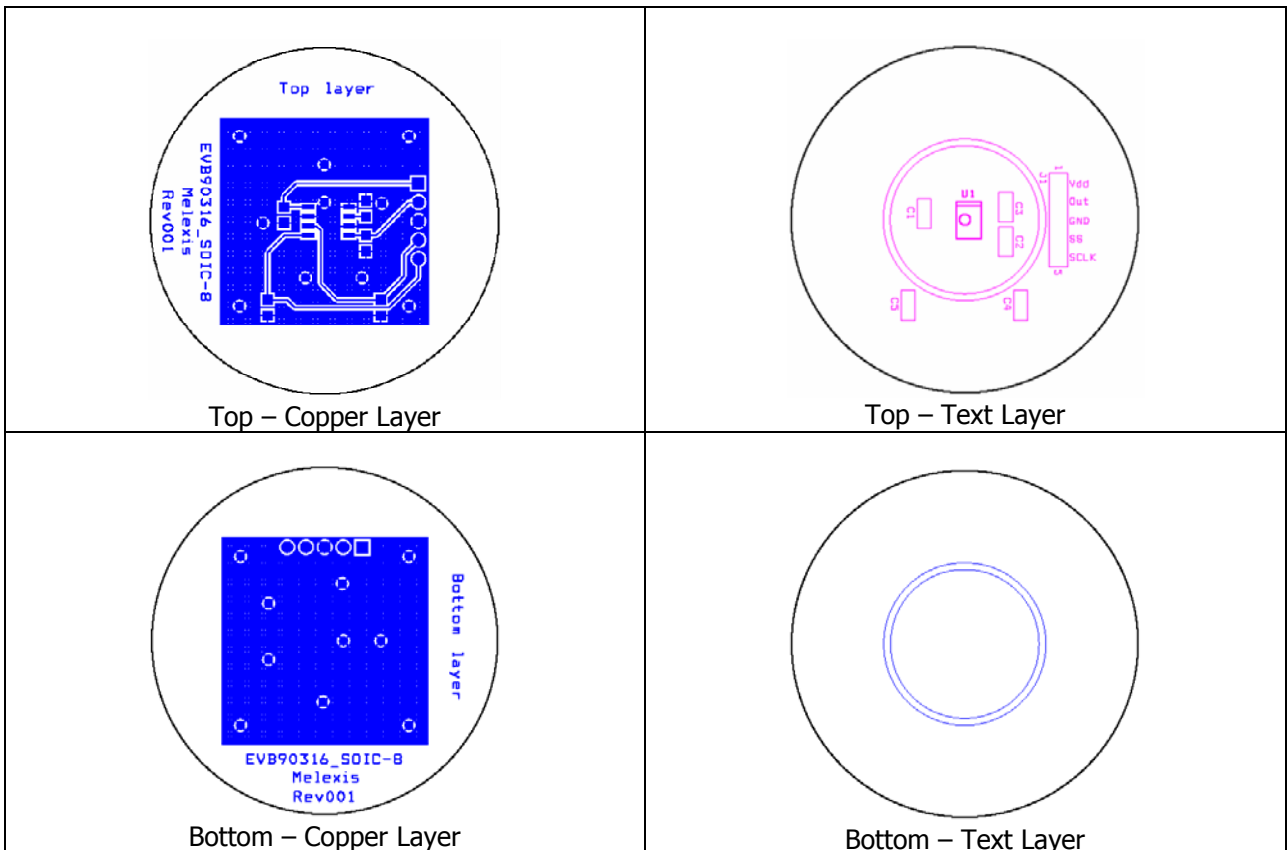

1.4. Magnetic Knob

The magnetic knob features a small SmCo magnet diametrically magnetized D6H2.5 (Diameter = 6 mm and Height = 2.5 mm).

1.5. Pictures

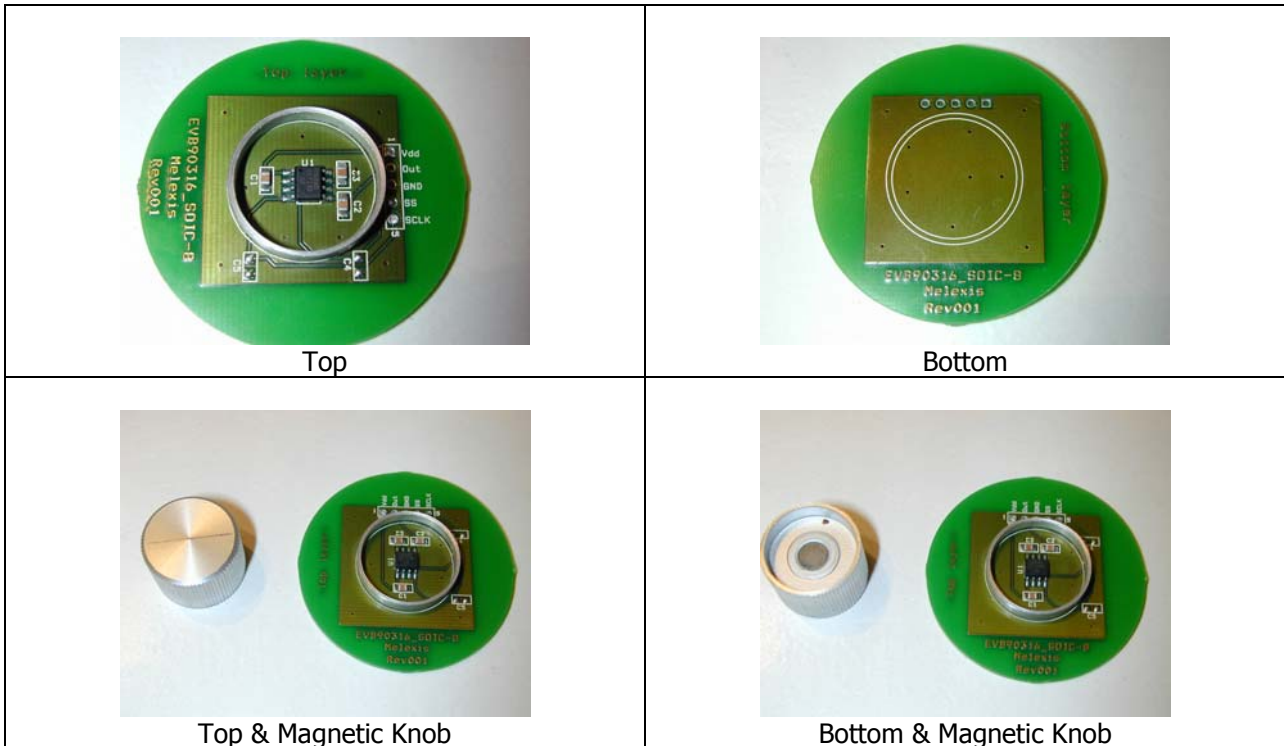

2. Evaluation Board (EVB_MLX90316GO)

2.1. Description

The EVB_MLX90316GO consists into a Printed Circuit Board (PCB) and Magnetic Knob.

- The PCB implements the recommended application diagram from the MLX90316 datasheet. The MLX90316GO (Full Redundant Version – TSSOP-16) is mounted on the board. It also includes an aluminum ring in order to center the magnetic knob (see below) above the sensitive area of MLX90316. By default, the output transfer characteristics are programmed to get a 10%Vdd ... 90%Vdd analog output swing for 0 ... 360 Degrees travel (complete revolution).
- The magnetic knob features a small SmCo magnet diametrically magnetized D6H2.5 (Diameter = 6 mm and Height = 2.5 mm).

2.2. Application Diagram

The EVB_MLX90316GO does not feature the Serial Protocol Option. It however enables the evaluation of the full redundant version of the MLX90316 as there are not any common pins for both dies.

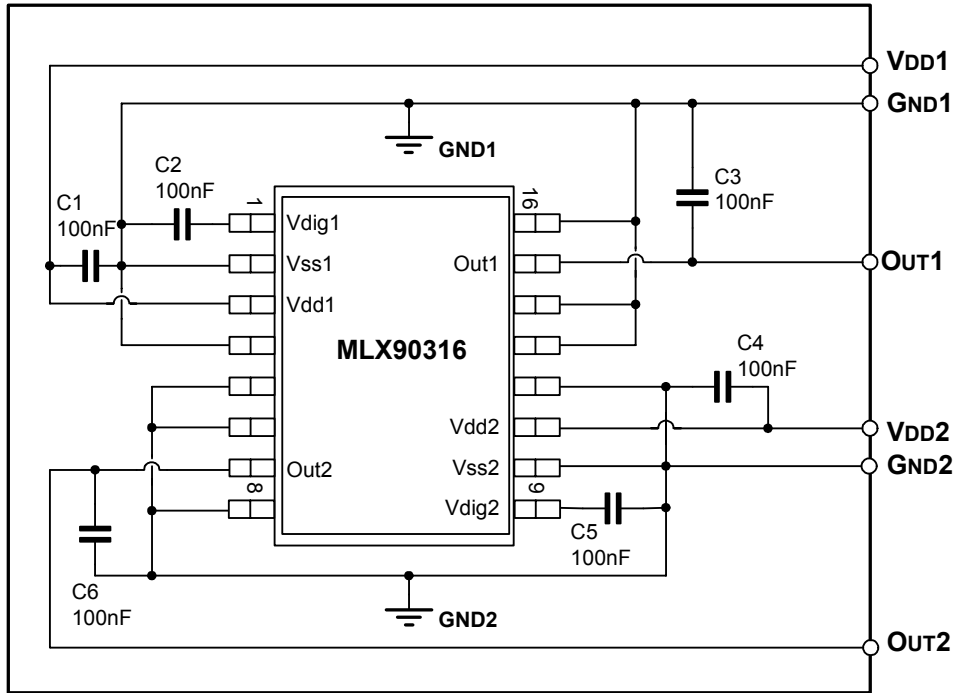

2.3. PCB Drawing

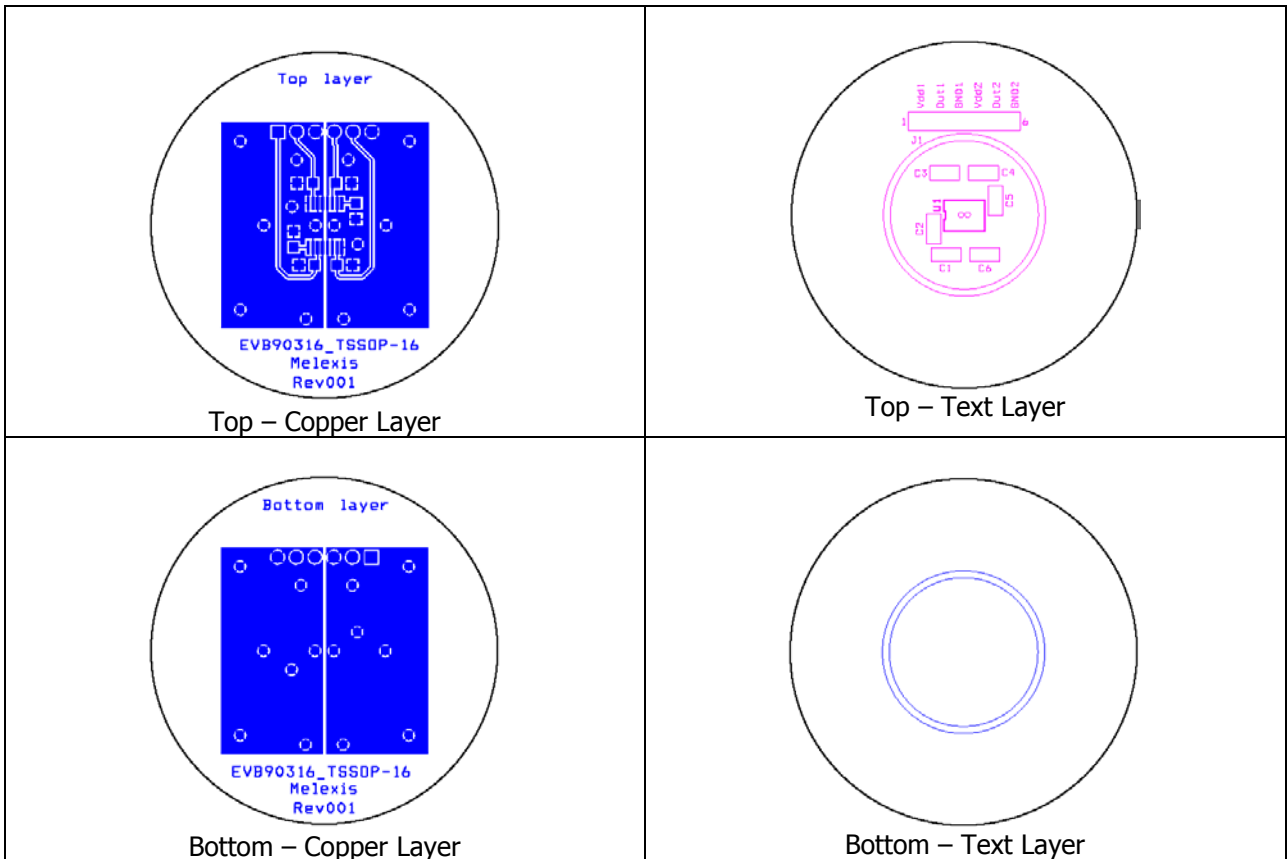

2.4. Magnetic Knob

The magnetic knob features a small SmCo magnet diametrically magnetized D6H2.5 (Diameter = 6 mm and Height = 2.5 mm).

2.5. Pictures



3. Demonstration Board (DMB_MLX90316)

3.1. Description

The DMB_MLX90316 consists into a Printed Circuit Board (PCB), Magnetic Knob and a digital voltmeter (DVM).

- The PCB implements the same application diagram as the EVB_MLX90316DC. The PCB also features an aluminum ring in order to center the magnetic knob (see below) above the sensitive area of MLX90316. The part is programmed to get a 1 V ... 4.6 V output swing for 0 ... 360 Degrees travel (i.e. 10 mV/Degree). This 3.6 V span is then further measured by the DVM (see below) after a resistive divider $1 \div 10$ (final sensitivity = 1 mV/Degree).
- The magnetic knob features a small SmCo magnet diametrically magnetized D6H2.5 (Diameter = 6 mm and Height = 2.5 mm).
- The digital voltmeter: measures 10% (resistive divider $1 \div 10$) of the output voltage and displays the value. The reading is in mV or in Degree given the sensitivity of 1 mV/Degree.

The board is either supplied from a 9 V battery or an external supply (+ 9 ... + 12 V).

3.2. Pictures

